

Electrofusion 22° Elbow

PE100 • SDR11 - SDR21 • PN16 WATER • 1000KPA GAS

SIZE	CODE	L	L1	D	D1
90	2124-0090	214	72	113	90
110	2124-0110	232	71	143	110
125	2124-0125	274	86	165	125
180	2124-0180	278	105	213	180

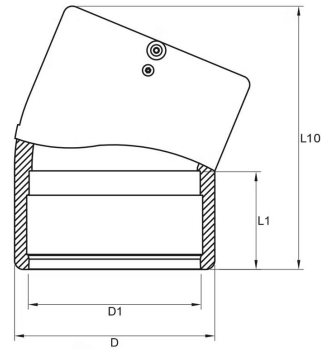

Comments:

Check that both pipe(s) and fitting to be joined are compatible, only compatible materials should be joined together. Check the PN and SDR rating marked on fitting and compare with that of the pipe. If in doubt, seek advice from the manufacturer. Correct installation procedures should be followed.

The designs, materials and specifications shown are subject to change without notice. This is due to the continuous development of our product range

Contact our technical team for further information.