

Electrofusion 45° Elbow

PE100 • SDR11 • SDR21 • PN16 WATER • 1000KPA GAS

SIZE	CODE	L	L1	D
25	2104-0025	99	39	44
32	2104-0032	108	41.5	44
40	2104-0040	124	44.5	53
50	2104-0050	137	50	64
63	2104-0063	165	54	78.5
75	2104-0075	165	60	94
90	2104-0090	213	75	117
110	2104-0110	240	81	137
125	2104-0125	287	89	154
160	2104-0160	290	90	201
180	2104-0180	350	90	222
200	2104-0200	350	90	243
225	2104-0225	377	100	274
250	2104-0250	421	109	304

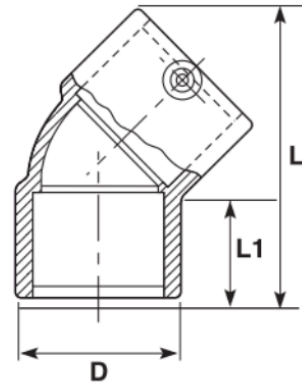

Comments:

Check that both pipe(s) and fitting to be joined are compatible, only compatible materials should be joined together. Check the PN and SDR rating marked on fitting and compare with that of the pipe. If in doubt, seek advice from the manufacturer. Correct installation procedures should be followed.

The designs, materials and specifications shown are subject to change without notice. This is due to the continuous development of our product range

Contact our technical team for further information.