

## Fabricated 45° Junction

PE100 - SDR11 - SDR26

SIZE (MM)	CODE PN8 SDR11	CODE PN5 SDR17	A (MM)	B (MM)	C (MM)
90	6694-0090	6696-0090	700	270	430
110	6694-0110	6696-0110	700	270	430
125	6694-0125	6696-0125	750	300	450
140	6694-0140	6696-0140	780	300	480
160	6694-0160	6696-0160	850	330	520
180	6694-0180	6696-0180	950	360	590
200	6694-0200	6696-0200	960	370	590
225	6694-0225	6696-0225	1080	420	660
250	6694-0250	6696-0250	1150	450	710
280	6694-0280	6696-0280	1250	500	750
315	6694-0315	6696-0315	1350	530	820
355	6694-0355	6696-0355	1450	570	880
400	6694-0400	6696-0400	1550	600	950
450	6694-0450	6696-0450	1850	650	1200
500	6694-0500	6696-0500	2100	700	1400
560	6694-0560	6696-0560	2200	800	1400
630	6694-0630	6696-0630	2300	800	1500

- Other sizes up to 1200mm and custom angle bends made to order.
- Derating applies - discuss with our sales team

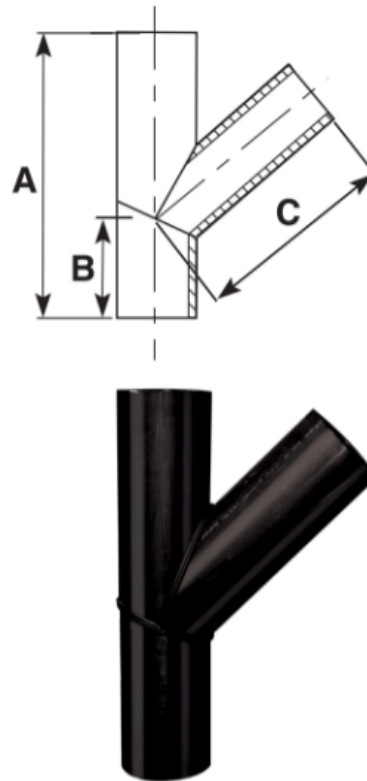

### Comments:

Check that both pipe(s) and fitting to be joined are compatible, only compatible materials should be joined together. Check the PN and SDR rating marked on fitting and compare with that of the pipe. If in doubt, seek advice from the manufacturer. Correct installation procedures should be followed.

The designs, materials and specifications shown are subject to change without notice. This is due to the continuous development of our product range

Contact our technical team for further information.