



HDPE RING SEAL ADAPTOR

200 - 315MM



Ultimate Solutions.
Intelligent Delivery.



DWV (PVC) to HDPE Ring Seal Adaptor

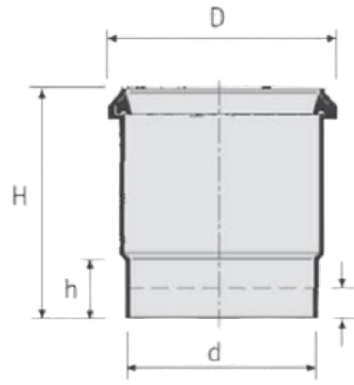

COMMENTS

- PVC pipe must be chamfered at end before insertion to avoid damage to rubber ring when installing
- Rubber ring must be adequately lubricated before insertion
- PVC pipe must cut straight and shall be inserted to full depth of the adaptor socket

This product has been inspected and/or manufactured in accordance with the below requirements, where relevant:

1. AS/NZS 4401
2. UNI EN1519

STANDARD COMPOSITION

- PVC Size: 175mm, 225mm, 300mm DWV
- HDPE Size: 200mmOD, 250mmOD, 315mmOD SDR26
- Rubber Ring: EDPM material
- Leg Length suitable for Electrofusion welding
- Operating temperature (-40°C to +70°C with peaks to 95°C for HDPE)
- Flow from HDPE to PVC or PVC to HDPE are both suitable for this adaptor

SIZE	175/200MM	225/250MM	300/315MM
Dimensions	<ul style="list-style-type: none"> • H = 400mm • h = 110mm • d = 200mm 	<ul style="list-style-type: none"> • H = 325mm • h = 62mm • d = 250mm 	<ul style="list-style-type: none"> • H = 355mm • h = 70mm • d = 315mm

WELLINGTON

17 Raiha Street, Porirua

AUCKLAND

3/68 McLaughlins Road, Wiri

P 0800 473 100

E sales@upg.net.nz

W upg.nz

