

## Spigot 45° Moulded Junction

PE100 • SDR11 PN16 - SDR17 PN10

SIZE	CODE SDR11	CODE SDR17	A	B	C
40	3194-0040	3196-0040	189	65	120
50	3194-0050	3196-0050	222	78	145
63	3194-0063	3196-0063	244	86	156
75	3194-0075	3196-0075	290	109	182
90	3194-0090	3196-0090	371	136	234
110	3194-0110	3196-0110	400	140	249
125	3194-0125	3196-0125	447	150	290
160	3194-0160	3196-0160	538	165	375
180	3194-0180	3196-0180	580	191	388
200	3194-0200	3196-0200	633	216	408
225	3194-0225	3196-0225	700	220	485
250	3194-0250	3196-0250	792	252	540
280	3194-0280	3196-0280	852	266	586
315	3194-0315	3196-0315	965	303	662

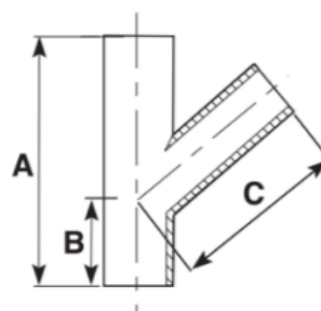

### Comments:

Check that both pipe(s) and fitting to be joined are compatible, only compatible materials should be joined together. Check the PN and SDR rating marked on fitting and compare with that of the pipe. If in doubt, seek advice from the manufacturer. Correct installation procedures should be followed.

The designs, materials and specifications shown are subject to change without notice. This is due to the continuous development of our product range

Contact our technical team for further information.