

Electrofusion Coupler PN10 Low Pressure

PE100 · PN10 WATER · 600KPA GAS

SIZE	CODE	L	L1	D	SDR RANGE
250	2016-0250	222	111	303	17-26
315	2016-0315	261	128	386	17-26
450	2016-0450	320	160	522	17-26
500	2016-0500	360	180	621	17-26
560	2016-0560	390	195	694	17-26
630	2016-0630	430	215	780	17-26
710	2016-0710	475	236	819	17-26
800	2016-0800	520	260	921	17-26
900	2016-0900	550	275	1035	17-26
1000	2016-1000	600	300	1149	17-26
1200	2016-1200	650	325	1376	17-26
1400	2016-1400	700	350	1603	17-26

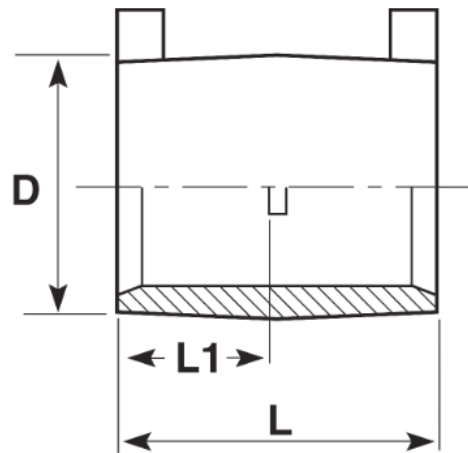

Comments:

Check that both pipe(s) and fitting to be joined are compatible, only compatible materials should be joined together. Check the PN and SDR rating marked on fitting and compare with that of the pipe. If in doubt, seek advice from the manufacturer. Correct installation procedures should be followed.

The designs, materials and specifications shown are subject to change without notice. This is due to the continuous development of our product range

Contact our technical team for further information.

Wellington
17 Raiha Street, Porirua

Auckland
3/68 McLaughlins Road, Wiri

P 0800 473 100
E sales@upg.net.nz
W upg.nz